

INTERIOR STAIR DETAIL

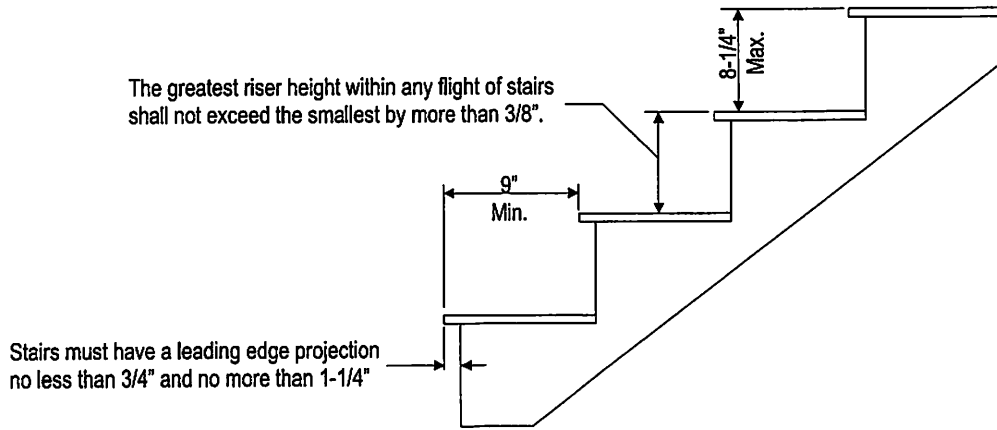

TREAD AND RISER DETAIL

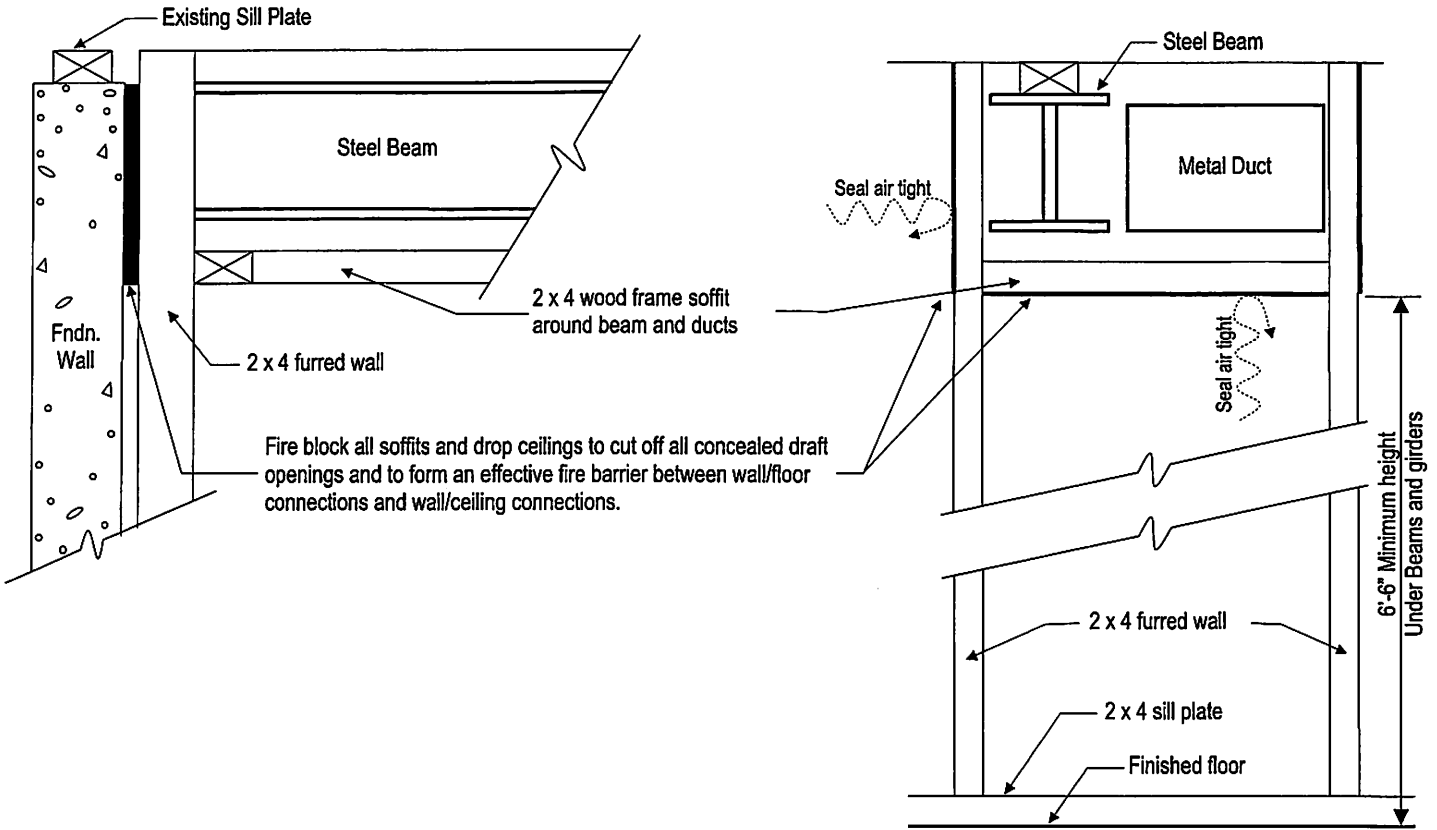

SOFFIT FIRESTOPPING DETAIL

Bars, grilles, covers, screens or similar devices are permitted to be placed over emergency escape openings or window wells provided they meet the minimum net clear opening requirements and such devices are releasable or removable from the inside without the use of a key, tool, special knowledge or force greater than that which is required for normal operation of the escape and rescue opening.

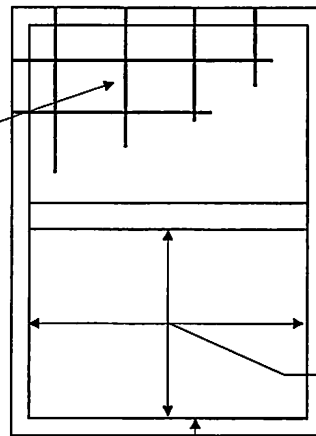

The emergency escape window must have a minimum opening of 5 square feet. The opening must be at least 20" wide and the height of the opening must be at least 24".

44" Max. sill height for egress (bedroom) windows measured from floor to top of sill.

Emergency escape and rescue openings shall be operational from the inside of the room without the use of keys, tools or special knowledge.

EMERGENCY ESCAPE WINDOW DETAIL

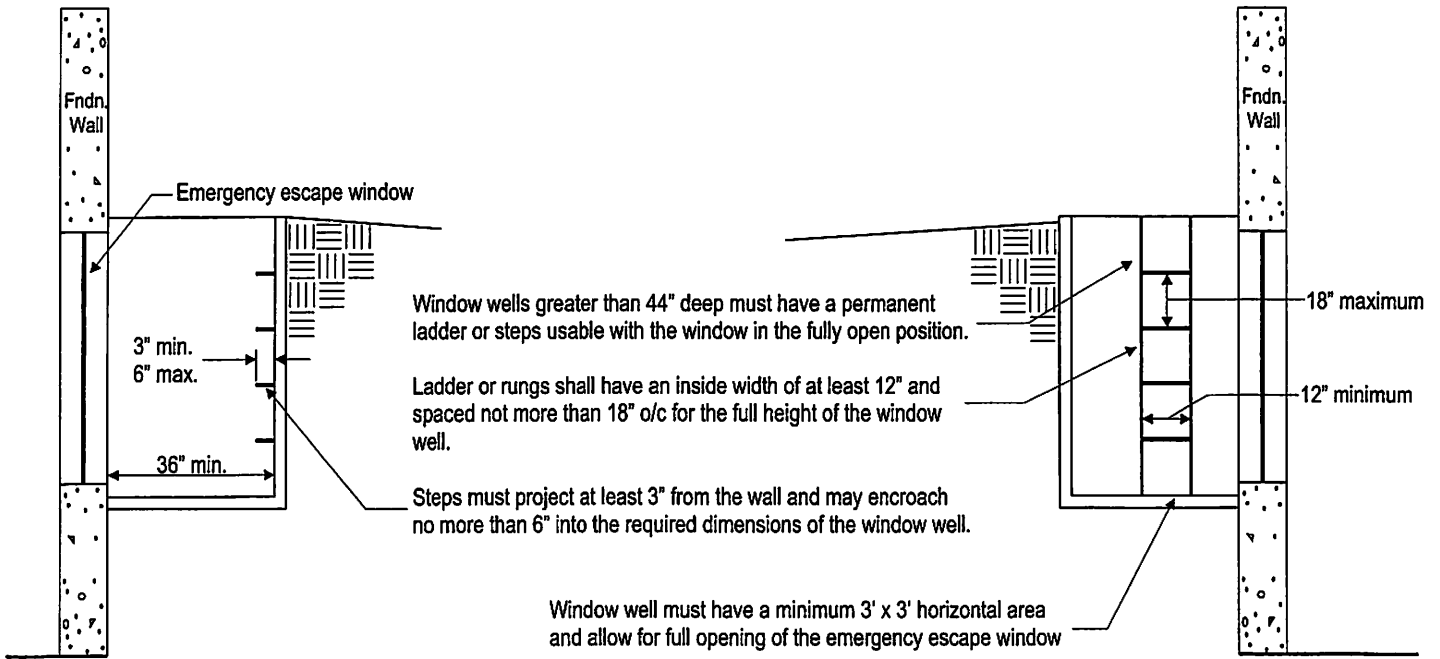

EMERGENCY ESCAPE WINDOW WELL DETAIL

SAMPLE BASEMENT PLAN/LAYOUT

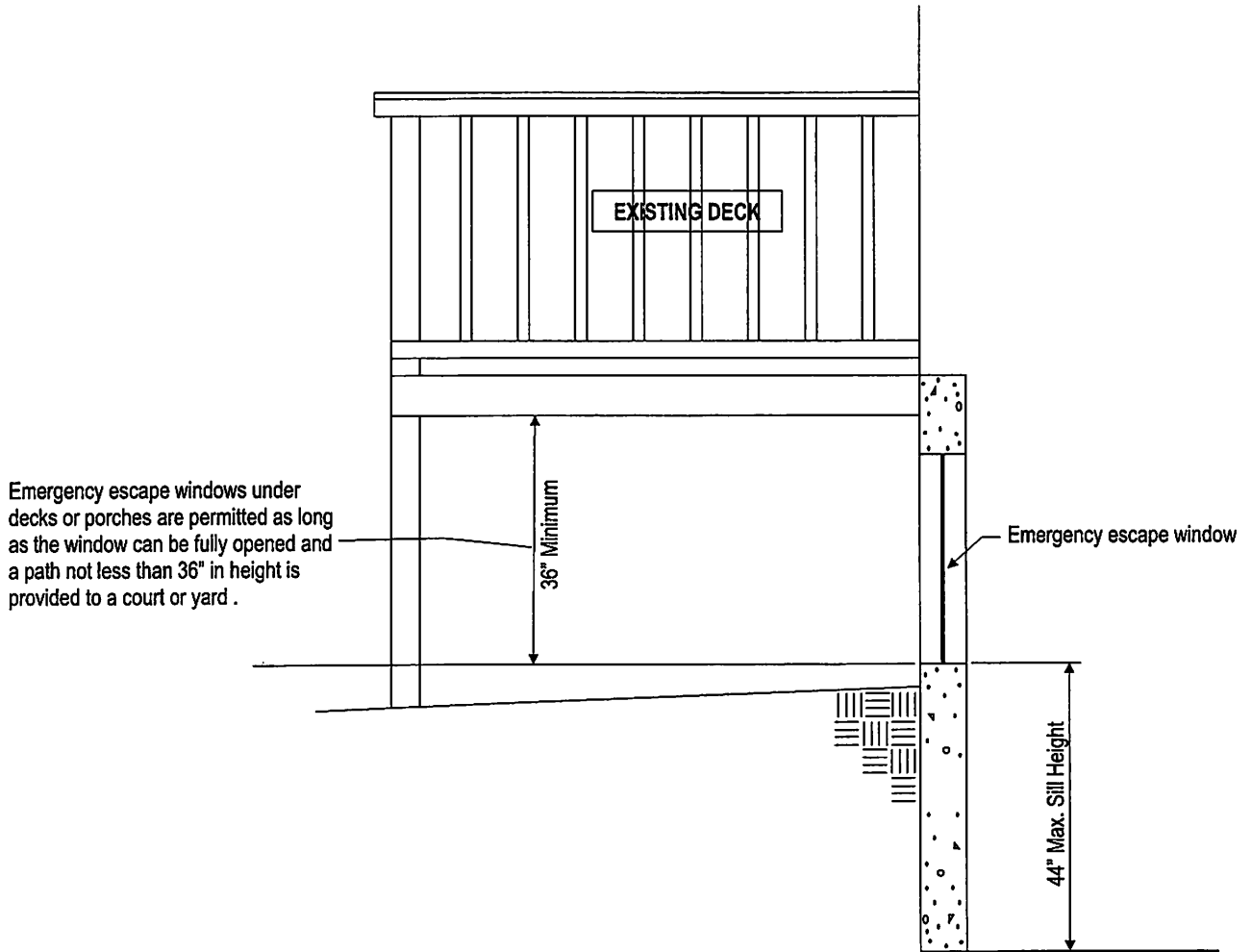

EMERGENCY ESCAPE WINDOW UNDER EXISTING STRUCTURES

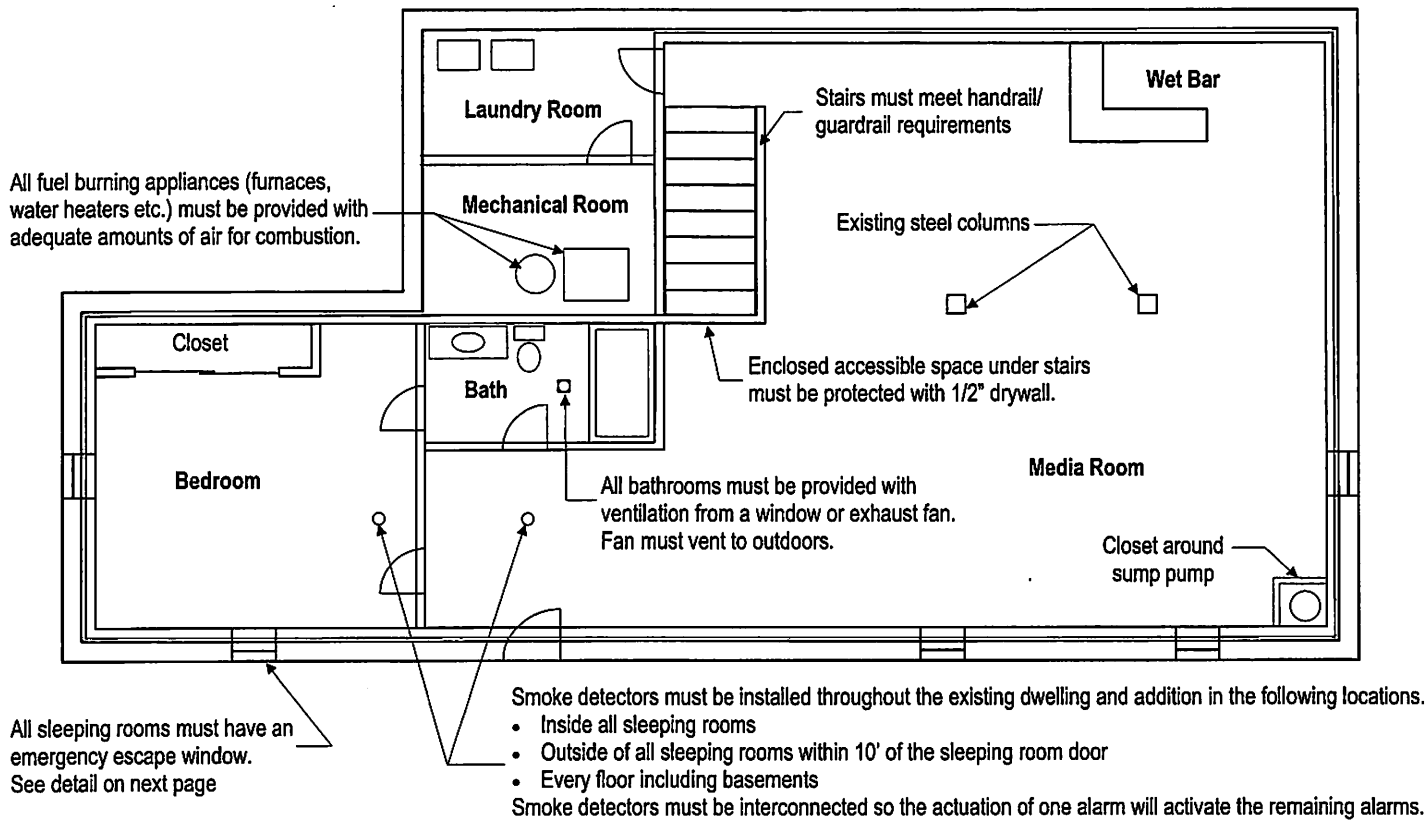

FLOOR PLAN FOR BASEMENT FINISH

SAMPLE BASEMENT PLAN/LAYOUT

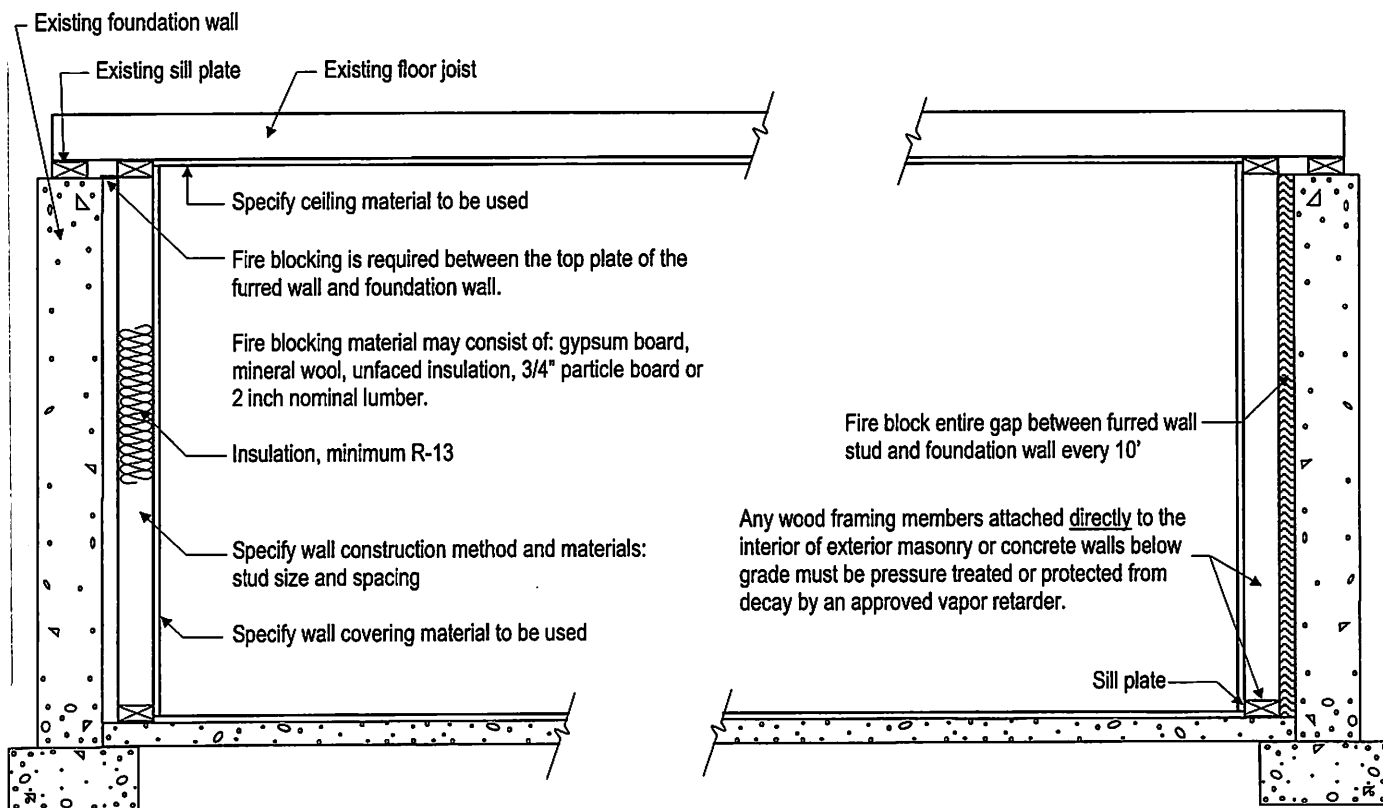

TYPICAL WALL SECTION